

1 Safety-related information

- Before using this product, carefully read the instructions for use.
- Strictly follow the instructions for use. The user must fully understand and strictly observe the instructions. Use the product only for the purposes specified in the intended use section of this document.
- Do not dispose of the instructions for use. Ensure that they are retained and appropriately used by the product user.
- Only trained and competent users are permitted to use this product.
- Comply with all local and national rules and regulations associated with this product.
- Only trained and competent personnel are permitted to inspect, repair, and service the product. Dräger recommend a Dräger service contract for all maintenance activities and that all repairs are carried out by Dräger.
- Use only genuine Dräger spare parts and accessories, or the functional integrity of the product may be impaired.
- Do not use a faulty or incomplete product, and do not modify the product.
- Notify Dräger in the event of any component fault or failure.
- Use of the breathing apparatus should be consistent with NFPA 1500 – Standard on Fire Department Occupational Safety and Health Program.
- All approved respiratory equipment shall be selected, fitted, used, and maintained in accordance with MSHA (Mine Safety and Health Administration), OSHA (Occupational Safety and Health Administration), and other applicable regulations.
- The air supply shall meet the requirements for breathing air according to CGA G – 7.1, Grade D or higher quality and, where appropriate, be in accordance with: NFPA 1989 Standard on Breathing Air Quality for Emergency Services Respiratory Protection.
- Before occupational use of this respirator a written respiratory protection program must be implemented meeting all the local government requirements. In the United States employers must comply with OSHA 29 CFR 1910.134 which includes medical evaluation, training, and fit testing.
- This device has been tested and complies with the FCC (Federal Communications Commission) and IC (Industrial Commission) rules. Changes or modifications to the product may render it non-compliant.

2 Conventions used in this document

2.1 Definitions of alert icons

Alert icons are used in this document to provide and highlight text that requires greater awareness by the user. A definition of the meaning of each icon is as follows:

WARNING
Indicates a potentially hazardous situation which, if not avoided, could result in death or serious injury.

CAUTION
Indicates a potentially hazardous situation which, if not avoided, could result in physical injury. It may also be used to alert against unsafe practices.

NOTICE
Indicates a situation which, if not avoided, could result in damage to the product or environment.

2.2 Trademarks

FPS® is a registered trademark of Dräger in the United States and/or other countries. Contact Dräger for details.

Procell® and Duracell® are registered trademarks of Duracell U.S. Operations, Inc. in the United States and/or other countries.

Panasonic® is a trademark of Panasonic Corporation, Japan, in the United States and/or other countries.

Dow Corning® and Molykote® are registered trade marks of Dow Corning Corporation in the United States and/or other countries.

Spur-Tex® is a registered trade mark of Spurrer Chemicals Companies, Inc. in the United States and/or other countries.

3 Description

The Dräger PSS 5000 Series is a breathing apparatus that provides the wearer with respiratory protection using an open-circuit, pressure-demand, compressed-air system. The apparatus can be used as a self-contained system, or with an independent air supply for supplied-air respirator (SAR) operations. The series is compatible with Dräger compressed air cylinders and the FPS® 7000 face mask. The product includes a Sentinel TX Gauge

3.1 Feature description

The carrying system has a carbon-composite backplate, with adjustable shoulder harness and waist belt connected using quick release connectors. The waist pad is connected at a flexible joint to compensate for the twisting and bending of the user.

All variants use the same first-stage regulator (Fig A, Item 5). The regulator supplies medium-pressure breathing air through a medium-pressure hose (Fig A, Item 6) and a quick coupling (Fig A, Item 2) to an attached lung demand valve (second-stage regulator). Incorporated in the first-stage regulator is a RIC UAC (rapid intervention crew universal air connection) (Fig A, Item 4), which is a male coupling that allows emergency refilling of the compressed air cylinder while wearer is breathing from the apparatus.

3.1.1 Sentinel TX Gauge

The Sentinel TX Gauge (Fig B) is a mechanical pressure gauge with a warning whistle and photoluminescent gauge face (Fig B, Item 4). The warning whistle sounds at the end-of-service-time (see Section 10 for the end-of-service-time indicator (EOSTI) activation pressures). The gauge face can be illuminated for approximately 3 seconds by a white LED located around the gauge face by pressing the illumination button (Fig B, Item 1). Green (Fig B, Item 2), amber (Fig B, Item 3), and red (located

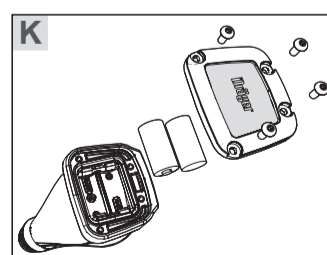
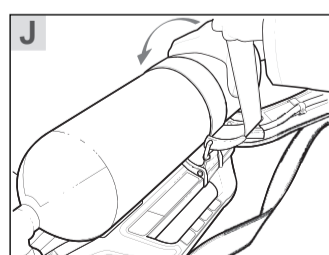
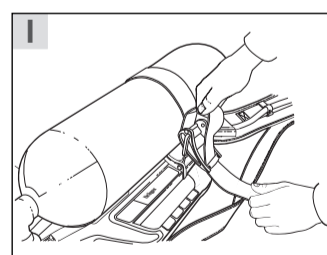
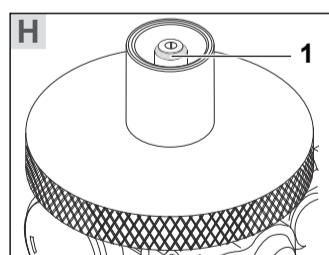
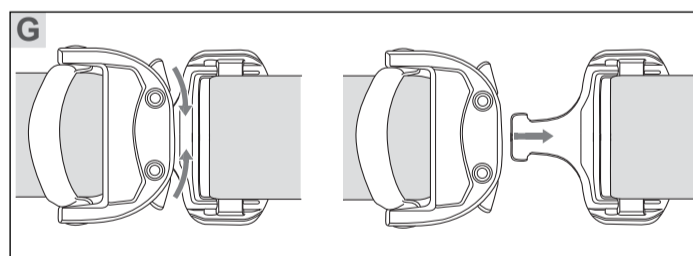
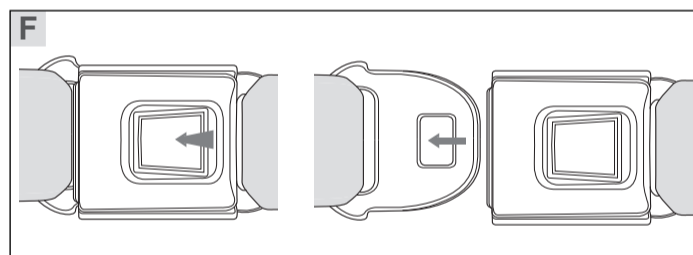
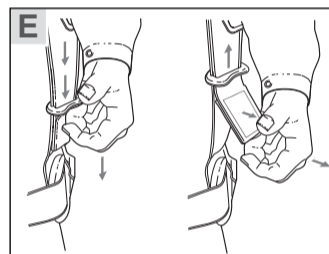
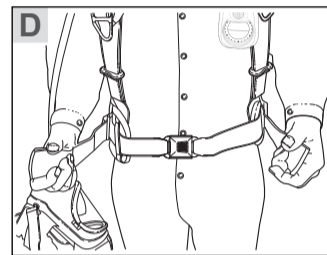
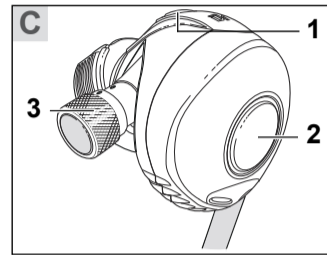
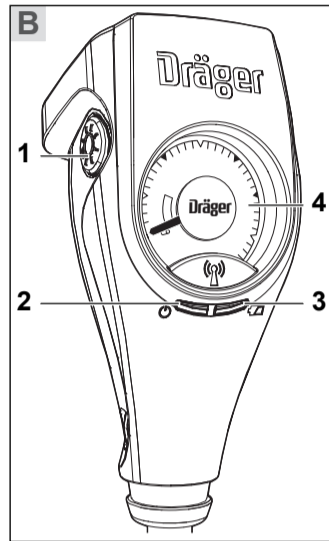
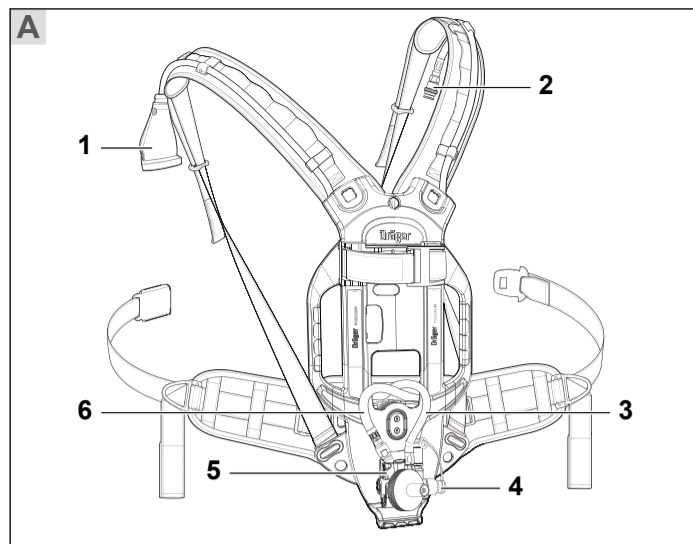

around the gauge face) LEDs give visual signals to the user (see Section 4.4.1 for more details).

The TX Gauge switches on automatically when the cylinder valve is opened if the pressure in the compressed air cylinder is approximately 145 psi or greater.

The TX Gauge has radio frequency (RF) communication circuitry that allows:

- Reading and reprogramming of the TX Gauge
- Wireless transmission of data to compatible devices
- Pairing of the TX Gauge with other compatible devices

Information that can be read from the TX Gauge includes device identity, a record of events (datalog), the current values for configurable parameters and the firmware version. Configurable parameters include intermediate pressure warning activation pressures, gauge illumination duration, etc. The parameters described in this document are the default for the device. Reading and reprogramming of the TX Gauge requires Dräger PC Link. Contact Dräger for details.

The TX Gauge has a short range RF wireless transmitter. This transmitter can transmit data (such as switch on/off signals, pressure values, etc.) to compatible devices (e.g. the FPS® 7000 HUD (head-up display)) that are within communication range. See the device instructions for use or contact Dräger for details.

The TX Gauge can be paired with compatible removable integrated Dräger Personal Alert Safety System (PASS) devices. Pairing ensures that the PASS will only respond to signals transmitted by the paired TX Gauge, and will ignore switch on/off signals transmitted from any other devices in range. More than one PASS device may be paired with a single TX Gauge. To check for paired devices within range, press and hold the illumination button for 10 seconds. See the PASS device instructions for use or contact Dräger for details of pairing the TX Gauge.

3.1.2 Compressed air cylinders, lung demand valves, and face masks

The PSS 5000 Series is compatible with composite material cylinders of 30 to 60 minute capacity, and is available in 2216 psi or 4500 psi versions. Full descriptions and user instructions are contained in separate instructions supplied with the cylinder, face mask, or lung demand valve.

3.2 Intended use

When the PSS 5000 Series is used with an approved lung demand valve, face mask and compressed air cylinder, the breathing apparatus provides a wearer with respiratory protection for working in contaminated or oxygen-deficient conditions.

The compressed air cylinder, lung demand valve, face mask, and other accessories used with this product must be certified Dräger components, assembled in an approved configuration, otherwise the operation of the device may be impaired. Contact Dräger for further information.

3.3 Approvals

The PSS 5000 Series is certified by NIOSH to 42 CFR Part 84. In certain combinations, the series is certified by NIOSH to provide respiratory protection from military grade chemical, biological, radiological, and nuclear hazards (CBRN). The series is also certified by SEI to meet the requirements of NFPA 1981:2018 and NFPA 1982:2018. The apparatus must only be used with compressed air cylinders approved by NIOSH and in the approved configuration in Section 4.

This device (model: Sentinel TX Gauge) complies with part 15 of the FCC Rules. Operation is subject to the following 2 conditions: 1) this device may not cause harmful interference, and 2) this device must accept any interference received, including interference that may cause undesired operation.

This device (model: Sentinel TX Gauge) complies with RSS-310 of Industry Canada. Operation is subject to the condition that this device does not cause harmful interference.

3.4 Explanation of type-identifying marking and symbols

NOTICE
The equipment may be damaged, or approvals invalidated, by engraving it, or by applying chemical marking or paint.
► Do not use marker pens or apply paint, and do not scratch or engrave the equipment.
► Dräger recommend using adhesive labels to add personal marking to the equipment.

Refer to the relevant authority for explanation of approval body symbols and marking on the equipment. Examples of other marking on component parts of the breathing apparatus are:

BRAC-1359	–	Dräger serial number
08/09	–	Month and year of manufacture
3356812 or R21034	–	Dräger part number
SF	–	Standard force coupling
LF	–	Low force coupling
☀	–	Illumination button
⏻	–	Green LED
⏻	–	Amber LED
📡	–	Radio frequency (RF) communication symbol

4 Use

WARNING
Only trained and competent users are permitted to prepare and use this equipment.
► Ensure that any accessories, ancillary equipment, and other protective clothing items do not interfere with the breathing apparatus and do not create a safety hazard.

The effective working duration of the apparatus depends on the initial air supply available and the breathing rate of the wearer.

- Fill compressed air cylinders to their full rated pressure before use.
- Do not commence any operation (including supplied-air respirator (SAR) operations) using a cylinder that is less than 90 percent full.

CAUTION
Equipment damage may cause the release of high-pressure air.

- ▶ Do not apply excessive force or use tools to open or close a cylinder valve.
- ▶ Do not drop or throw down the breathing apparatus.

4.1 Prerequisites

Refer to the following additional information before preparing or using the breathing apparatus:

- The special instructions (see Section 11).
- For non-CBRN use, see the separate NIOSH approval table 3367114 for approved configurations.
- For CBRN use, see the separate NIOSH CBRN approval table 3367113 for approved configurations. For CBRN use, the user must also refer to the CBRN special instructions in the lung demand valve instructions for use.

The TX Gauge battery cover and batteries are supplied unfitted. Install the batteries and fit the battery cover before use (see Section 4.6.2).

4.2 Preparation for use

Replace the batteries if the device fails to operate, or if a low battery alarm activates.

1. Carry out a visual inspection of the apparatus (see Section 4.6.1).
2. Install the TX Gauge batteries if necessary (see Section 4.6.2).
3. Fit the compressed air cylinder (see Section 4.6.3).
4. Press the male coupling of the lung demand valve hose into the female coupling of the medium-pressure hose until an audible click is heard (do not connect the valve to the face mask at this stage).
5. Press the reset button (Fig C, Item 1) to switch off the positive pressure. Press and rotate the bypass button (Fig C, Item 3) to align the red spots and then release the button to switch off the bypass.
6. Pair the TX Gauge with one or more compatible PASS devices if necessary (see the PASS device instructions for use).
7. Carry out a full functional test of the apparatus (see Section 4.6.4).
8. Align and push the lung demand valve into face mask port until it latches in position, and check the attachment by gently attempting to pull the coupling apart.

4.3 Putting on the breathing apparatus

1. Fully loosen the shoulder harness and waist belt and put on the breathing apparatus.
2. Check that the shoulder pads are not twisted and take the weight of the system on the shoulders by pulling the shoulder harness. Do not fully tighten at this stage.
3. Close the waist belt buckle and pull the ends of the waist belt forward until the strap padding fits securely and comfortably over the hips (Fig D). Tuck the belt ends behind the waist pad.
4. Pull the shoulder harness until the breathing apparatus rests securely and comfortably on the hips. Do not over tighten. Pull the strap retainers down to secure the strap ends (Fig E).
5. Fully loosen the head straps of the face mask and place the neck strap over the back of the neck.
6. Press the reset button (Fig C, Item 1) to switch off the positive pressure.
7. Open the cylinder valve (counterclockwise) slowly, but fully, to pressurize system. TX Gauge automatically switches on and performs a self-test.
 - If the self-test passes, the green LED will flash once every second to indicate that the TX Gauge is switched on.
 - If the self-test fails, the amber LED will flash once every 2 seconds for 10 seconds. Report the fault to trained service personnel. Do not use the breathing apparatus until the fault condition is rectified.
- After storage at temperatures below 32 °F (0 °C) leakage may be observed when the cylinder valve is initially opened due to ice formation.
 - If leakage is observed from the lung demand valve, press the front button (Fig C, Item 2) to allow a rush of air to pass through the lung demand valve and then quickly press the reset button (Fig C, Item 1) to switch off the positive pressure. Resume normal operation.
 - If leakage is observed from the quick connect coupling, close the cylinder valve and vent the system. Disconnect then reconnect the cylinder to the breathing apparatus (see the quick connect coupling instructions for use), then reopen the cylinder valve slowly, but fully, to pressurize the system. Resume normal operation.
 - If leakage still occurs, remove the breathing apparatus from service and report the fault to trained service personnel or contact Dräger.

WARNING
If there is not a good seal between the mask and the face of the wearer, the mask may leak inward or outward during use.

- ▶ In a CBRN environment, use only face mask sizes that have been confirmed by a quantitative fit test (QNFT).

8. Put on the face mask and check the seal between the mask and face of the wearer (for non-CBRN use see the Dräger FPS® 7000 face mask instructions for use; for CBRN use see the CBRN special instructions in the lung demand valve instructions for use).

4.4 During use

WARNING
Users should be in a safe area before the whistle or end-of-service-time warnings commence.

- ▶ Fully open all cylinder valves and ensure that they remain open during use.
- ▶ Evacuate to a safe area immediately if warnings commence during an operation.

- Regularly check the remaining cylinder pressure on the gauge.
- Press the illumination button (Fig B, Item 1) to illuminate the gauge face.
- React to the following alarm and warning signals as necessary:
 - EOSTI – The mechanical warning whistle in the TX Gauge sounds, and the red LED flashes. The warning whistle and red LED will activate within the preset pressure range (see EOSTI Alarms in Section 10). Due to the activation tolerance, they may not activate at exactly the same time. The red LED will switch off when the pressure in the compressed air cylinder drops below

116 psi. The warning whistle will continue to sound until the compressed air cylinder pressure reaches zero.

- Low battery – The amber LED (Fig B, Item 2) will flash once every 5 seconds.

WARNING
Using the bypass button (Fig C, Item 3) uses air from the cylinder and may rapidly reduce the working duration of the apparatus.

- ▶ Do not use the bypass button unless absolutely necessary.

- If additional air is required, briefly press and release the bypass button (Fig C, Item 3) to deliver a single jet of air into the face mask.

WARNING
The following emergency air flow procedures may greatly reduce the operating duration of the air supply.

- ▶ When activated the user must immediately evacuate to a safe area.
- ▶ The reason for using the procedure must be investigated and repaired before reusing the breathing apparatus.

- Additional air flow required (emergency procedure only used in the unlikely condition of low or blocked airflow) – Press and rotate the bypass button (Fig C, Item 3) to deliver a sustained air supply (85 to 130 liters/minute) into the face mask.
- Excessive or loss of air flow (emergency procedure only used in the unlikely condition of high or loss of airflow) – Close the cylinder valve then immediately begin to slowly reopen the valve. Use the cylinder valve as a regulating valve to set the air flow to meet the user requirement. This procedure can be used with screw-type and ratchet-type cylinder valves.

4.4.1 Sentinel TX Gauge visual signals

The visual signals provided by the TX Gauge are shown in the following table.

Visual signal	Explanation
Flashing green LED	TX Gauge is switched on
Flashing red LED	Low cylinder pressure
Flashing amber LED once every 5 seconds	Low battery
Flashing amber LED at 2 second intervals for 10 seconds	Failed self check or hardware fault
Solid green LED	Attempting to establish communication with Dräger PC Link
Flashing green and amber LEDs	Communicating with Dräger PC Link
Solid green and white LEDs; flashing red LED	Attempting to pair with a PASS device
Alternating flashing white and green/amber LEDs	Successfully paired with a PASS device
Alternating flashing red and amber LEDs	Unable to pair with a PASS device

4.5 After use

WARNING
Removing the breathing apparatus in a hazardous breathing environment is unsafe.

- ▶ Do not remove the breathing apparatus until in a safe breathing environment.

NOTICE
The equipment can be damaged if removed incorrectly.

- ▶ Do not remove the face mask by pulling on the lung demand valve.

1. Loosen the face mask straps. At the point when the seal between the face mask and the face is broken, press the reset button (Fig C, Item 1) to switch off the positive pressure. Fully remove the face mask and extend all the straps of the head harness.
2. Close the cylinder valve.
3. Press the front button (Fig C, Item 2) to vent system and then press the reset button (Fig C, Item 1) to switch off the positive pressure. The TX Gauge will switch off automatically when the pressure drops below 116 psi. As the TX Gauge switches off, it transmits a signal. Paired devices that receive the signal will either switch off or indicate that they have logged off from the breathing apparatus (see the device instructions for use).
4. Release the waist belt buckle (Fig F or Fig G).
5. Lift the shoulder harness ends to release the strap retainers (Fig E) and then lift the shoulder harness buckles to loosen the straps.
6. Remove the breathing apparatus and face mask.
7. If the lung demand valve has been set to bypass, press and rotate the bypass button (Fig C, Item 3) to align the red spots and then release to switch off the bypass.
8. Carry out the after use tasks in the maintenance table (see Section 6.1).
9. Remove the compressed air cylinder if necessary (see Section 4.6.3).
10. Pass the breathing apparatus to the service department with details of any faults or damage that occurred during use.

4.6 Common user tasks

4.6.1 Visual inspection

A visual inspection must check the full breathing apparatus including all component parts and accessories. Check that the equipment is clean and undamaged, paying particular attention to pneumatic system components, hoses, and connectors. Typical signs of damage that may affect the operation of the breathing apparatus include impact, abrasion, cutting, corrosion, and discoloration. Report damage to service personnel and do not use the apparatus until faults are rectified.

4.6.2 Fitting or replacing the batteries

WARNING
Improper handling and use of batteries may cause an explosion, a fire, or a chemical hazard.

- ▶ Do not remove or install the batteries in a flammable atmosphere.
- ▶ Do not expose the batteries to heat sources.
- ▶ Do not attempt to recharge any non-rechargeable battery.
- ▶ Do not short out the battery terminals.
- ▶ Use only the recommended battery type.
- ▶ Replace batteries as a matched set and do not mix new and used batteries.

NOTICE
Batteries that are not correctly disposed of may cause an environmental hazard.

- ▶ Dispose of used batteries in accordance with national or local regulations.

- The normal operating life of the batteries depends on operating time, frequency of alarms and ambient temperature.
- Remove discharged batteries from the product.
- To preserve the datalog clock, install new batteries within 3 minutes of removing the discharged batteries.
- Use only the following approved battery type: Panasonic® CR123AL/1BP (3 V).

1. Remove the four screws using a 2.5 mm hexagon key, and remove the battery cover (Fig K).
2. Remove the discharged batteries and install a new set observing the polarity marked inside the battery compartment.
3. Check the cover and sealing ring. Lightly coat the sealing ring with Dow Corning® Molykote® 111 silicone grease (as a guideline, the grease should be felt on the fingers but not seen).
4. Refit the battery cover and screws. Do not over tighten the screws: Dräger recommend torque of 0.5 lbf ft (0.7 Nm).

4.6.3 Fitting or removing the compressed air cylinder

WARNING
High-pressure air release may cause injury to the user or other personnel near the breathing apparatus.

- ▶ Close the cylinder valve and fully vent the system before attempting to disconnect an compressed air cylinder.

Impact damage to the cylinder valve or first-stage regulator connector may prevent valve connection or cause an air leak.

- ▶ Handle the compressed air cylinder and breathing apparatus with care.

The following instructions are for a threaded cylinder coupling. See the quick connect coupling instructions for use for details of fitting and removing a quick connect coupling.

Fitting the cylinder

1. Check the threads of the cylinder valve port and the first-stage regulator. Ensure that the O-ring seal (Fig H, Item 1) in the first-stage regulator is clean and undamaged.
2. Lay the backplate horizontal, with the first-stage regulator uppermost, and fully extend the cylinder strap.
3. Insert the cylinder through the loop of the strap, and align the valve with the regulator.
4. Lift the cylinder and backplate into the vertical position (supported on the end of the cylinder opposite the valve).
5. Tighten the hand wheel of the regulator, using only the thumb and index finger, until a definite metal-to-metal contact is felt. Do not use tools or over tighten.
6. Place the unit back into the horizontal position.
7. Take up the slack in the cylinder strap (Fig I).
8. Pull the strap over the cylinder to operate the cam-lock buckle (Fig J) and secure using the hook-and-loop fastener.

Removing the cylinder

1. Close the cylinder valve and press the front button (Fig C, Item 2) to fully vent the system.
2. Lay the backplate horizontal, with the cylinder uppermost.
3. Remove the free end of the cylinder strap from the hook-and-loop fastener.
4. Lift the strap against the cam-lock buckle to release the buckle tension and loosen the strap.
5. Disconnect the cylinder valve from the first-stage regulator.
6. Lift the cylinder away from the first-stage regulator and remove the cylinder.

4.6.4 Functional testing

WARNING
Failure of the equipment to meet any of the standards or parameters in the functional test, or any visible signs of damage, indicates a possible system fault.

- ▶ Do not use the equipment and report the fault to trained maintenance personnel or contact Dräger.

1. Press the reset button (Fig C, Item 1) to switch off the positive pressure. Press and rotate the bypass button (Fig C, Item 3) to align the red spots and then release the button to switch off the bypass.
2. Open the cylinder valve (counterclockwise) slowly, but fully, to pressurize system. The TX Gauge will switch on automatically, and the warning whistles will briefly sound.
3. Fully close the cylinder valve.
4. After 20 seconds, reopen the cylinder valve while observing the gauge. The gauge must not show an increase of more than 300 psi.
5. Fully close the cylinder valve.
6. Cover the outlet port of the lung demand valve with the palm of the hand and press the front button (Fig C, Item 2).
7. Carefully lift the palm of the hand to slowly vent the system until the EOSTI alarms activate, and observe the pressure displayed on the gauge.
8. The warning whistles and red LED must activate within the preset pressure range (see EOSTI Alarms in Section 10). Due to the activation tolerance, they may not activate at exactly the same time.
9. Allow the system to fully vent. The red LED will switch off when the pressure in the compressed air cylinder drops below 116 psi. The warning whistles will continue to sound until the compressed air cylinder pressure reaches zero.
10. Press the reset button (Fig C, Item 1) to switch off the positive pressure.

5 Troubleshooting

The troubleshooting guide shows fault diagnosis and repair information applicable to breathing apparatus users. Further troubleshooting and repair information is available in instructions for use supplied with associated equipment.

Where the troubleshooting guide shows more than one fault or remedy, carry out repair actions in the order that they appear in the table.

Contact service personnel or Dräger when the remedy information indicates a service task, or if the symptom remains after all remedy actions have been attempted.

Symptom	Fault	Remedy
Face mask air leak	Lung demand valve O-ring leaking	Replace or lubricate O-ring
	Head straps not tight	Tighten
	Exhalation valve leaking	Service task
	Speech diaphragm defective	Service task
	Speech diaphragm defective	Service task
Unsatisfactory communication	Speech diaphragm defective	Service task
High-pressure air leak or failed leak test	Loose or dirty connector	Disconnect, clean, and reconnect couplings, and retest
	Faulty hose or component	Substitute user replaceable accessories and retest
Air leak from medium-pressure hose connection at the first-stage regulator (excess flow valve)	Faulty O-ring, retainer, spring, or first-stage regulator	Service task
Air leak from lung demand valve	Ice particles on sealing elements	Press the front button (Fig C, Item 2), allow a rush of air to pass through the valve, then quickly press the reset button (Fig C, Item 1) to switch off the positive pressure.
Air leak from quick connect coupling	Ice particles on sealing elements	Disconnect then reconnect the cylinder to the breathing apparatus (see the quick connect coupling instructions for use) and retest.
Lung demand valve allowing constant air flow into the face mask	Bypass button engaged	Turn off the bypass button (Fig C, Item 3)
	Internal fault	Service task
High or low medium-pressure	First-stage regulator fault	Service task
Poor sounding whistle	Whistle dirty	Clean whistle flute and retest
Whistle not functioning correctly	Activation mechanism fault	Service task
TX Gauge fails to switch on	Low batteries	Replace the batteries
	Low cylinder pressure	Recharge cylinder to maximum working pressure
	Unknown	Service task
Amber LED flashing every 5 seconds	Low batteries	Replace the batteries
Amber LED flashing every 2 seconds for 10 seconds	Failed self-test, or hardware fault	Service task
TX Gauge face difficult to see through window	Dirt on gauge face window	Clean gauge face window (see Section 6.2)
	Gauge face window damaged	Service task

6 Maintenance

6.1 Maintenance table

Service and test the breathing apparatus, including out-of-use apparatus, in accordance with the maintenance table. Record all service details and testing. Refer also to the instructions for use for the lung demand valve, face mask, and other associated equipment.

Additional inspection and testing may be required in the country of use to ensure compliance with national regulations.

Component/system	Task	After use	Every month	Every year
Complete apparatus	Clean and disinfect (see Section 6.2)	○		
	Visual inspection (see Section 4.6.1)	○	○	
	Functional testing (see Section 4.6.4)	○	○	
	Breathing cycle and static tests (see Note 1)			○
Lung demand valve	Clean and disinfect (see Note 2 and Section 6.2)	○		
First-stage regulator	Medium-pressure check (see Note 1)			○
	Inspect the high-pressure O-ring (see Note 1 and Note 3)			○
Cylinder	Charge cylinder to correct working pressure	○		
	Check charged pressure (stored cylinders only)		○	
	Check test date of cylinder (carbon composite cylinders over 15 years old must be retired)		○	
	Recertification			According to national regulations in the country of use
Cylinder valve	Overhaul			At the time of cylinder recertification

Notes

○ Dräger recommendations

- These maintenance tasks may only be carried out by Dräger or trained service personnel. Details of the tests are contained in the Technical Manual which is issued to service personnel that have attended a relevant Dräger maintenance course.
- Lightly lubricate the O-ring of the lung demand valve as required (recommended lubricant is Dow Corning® Molykote® 111). Products other than the recommended lubricant are not tested and may damage the equipment.
- Replace the high-pressure connector O-ring if it is found to leak during functional testing or if the O-ring is visibly damaged.

6.2 Cleaning and disinfecting

CAUTION

Trapped water and ice inside the pneumatic system (such as the lung demand valve) may impair the operation of the breathing apparatus.
 ► Prevent any liquid from entering the pneumatic system, and thoroughly dry the breathing apparatus after cleaning and disinfecting.

NOTICE

Cleaning agents and disinfectants listed in this section are not manufactured by Dräger and have been reviewed only for compatibility when used to clean or disinfect the subject Dräger products.
 ► Read and comply with all safety precautions provided by the manufacturers of such agents and disinfectants.

Using cleaning and disinfecting methods not described in this section may damage the equipment.

- Do not exceed 86 °F (30 °C) for washing, disinfecting, and rinsing solutions.
- Do not exceed 140 °F (60 °C) for drying, and remove components from the drying facility immediately when dry. Drying time in a heated dryer must not exceed 30 minutes.
- Do not immerse pneumatic or electronic components in cleaning solutions or water.

Refer also to the instructions for use for the lung demand valve, face mask, and other associated equipment.

6.2.1 Manual cleaning of the breathing apparatus (USA)

Cleaning and disinfecting materials:

- Cleaning agent – 1008 Green Liquid Hand Dish Wash.
- Disinfecting agent – 800 Spur-Tex® Disinfectant Cleaner-Deodorant (concentration: 1.6 % (2 fl oz per gallon)).
- Use only clean lint-free cloths.

- Prepare cleaning solution as per manufacturer's instructions. Clean the breathing apparatus manually using a cloth moistened with cleaning solution to remove excess dirt.
- Prepare disinfecting solution as per manufacturer's instructions. Apply to all internal and external surfaces, ensuring that all surfaces remain visibly wet for 15 minutes.
- Rinse all components thoroughly with clean water to remove all cleaning and disinfecting agents.
- Dry all components using a dry cloth, in a heated dryer or in air.
- Contact service personnel or Dräger if disassembly of the pneumatic system or electronic components is required.

6.2.2 Manual cleaning of the breathing apparatus (Canada)

Cleaning and disinfecting materials:

- Cleaning agent – mild soap solution.
- Disinfecting agent – Neutral Disinfectant Cleaner (concentration: 0.5 % (0.5 fl oz per gallon or 15 mL per 3.785 liters)).
- Use only clean lint-free cloths.

- Prepare cleaning solution as per manufacturer's instructions. Clean the breathing apparatus manually using a cloth moistened with cleaning solution to remove excess dirt.
- Prepare disinfecting solution as per manufacturer's instructions. Apply to all internal and external surfaces, ensuring that all surfaces remain visibly wet for 10 minutes.
- Rinse all components thoroughly with clean water to remove all cleaning and disinfecting agents.
- Dry all components using a dry cloth, in a heated dryer or in air.
- Contact service personnel or Dräger if disassembly of the pneumatic system or electronic components is required.

6.2.3 Carrying harness – Thorough cleaning

NOTICE

Untrained personnel are not permitted to disassemble the breathing apparatus as they could inadvertently damage the equipment.
 ► Thorough cleaning may only be carried out by suitably trained personnel.

- Remove the harness from the carrying system and clean using one of the following methods:
 - Clean manually in a bath containing recommended cleaning or disinfecting agents.
 - Machine wash (at 86 °F (30 °C)) using a proprietary brand washing solution (do not use biological washing powder).
- Rinse the harness thoroughly with clean water to remove all cleaning and disinfecting agents.
- Dry all components including internal parts.

6.3 Maintenance work

6.3.1 Compressed air cylinder charging

WARNING

Air quality for compressed air cylinders must conform to the minimum grade requirements for Type 1 gaseous air as defined in the CGA Commodity Specification for Air, G-7.1 (Grade D or higher quality) and, where appropriate, be in accordance with: NFPA 1989 Standard on Breathing Air Quality for Emergency Services Respiratory Protection.
 ► Ensure that the air supply meets these requirements.

Refer to the instructions supplied with the cylinder and the charging apparatus for recharging a compressed air cylinder.

7 Transport

Transport the product in its original packaging.

8 Storage

8.1 Storage preparation

- Extend the shoulder harness, waist belt, and the straps of the face mask.
- For storage, place the face mask in a protective bag (contact Dräger for supply of a suitable bag).
- Route pneumatic hoses in such a way that the bend radius is not too acute and the hose is not stretched, compressed, or twisted.
- With the system switched off, a small amount of battery power is consumed. If the system is not to be used for a long period, remove the

batteries (see Section 4.6.2). The datalog clock will stop a short time after the batteries are removed.

8.2 Storage conditions

- Store the equipment between 5 °F to 77 °F (-15 °C to +25 °C). Ensure that the environment is dry, free from dust and dirt, and does not subject the equipment to wear or damage due to abrasion. Do not store the equipment in direct sunlight.
- Fix the breathing apparatus securely to any raised mounting point to prevent it from falling.

9 Disposal

Dispose of the product in accordance with the applicable rules and regulations.

10 Technical data

Compressed air cylinders:

- 30 minutes to 60 minutes capacity.
- 2216 psi or 4500 psi pressure.
- Composite materials.

Operating pressures:

- Gauge operating pressure: 0 to 3000 psi, or 0 to 5000 psi.
- Atmospheric operating pressure: 11 to 29 psi.

Cylinder high-pressure connectors:

- 2216 psi connector to CGA 346.
- 4500 psi connector to CGA 347.
- Quick connect coupling (2216 psi or 4500 psi).

Gauge power supply:

- Battery: Panasonic® CR123A (3 V lithium).
- Voltage: 6 Vdc.

RIC UAC Connector:

- 2216 psi or 4500 psi, male, quick coupling with relief valve.

Lung demand valve to face mask connector:

- Dräger push-in connector.

EOSTI Alarms – Activation commencement range (mechanical and electronic):

- 2216 psi cylinder: 819 psi to 732 psi.
- 4500 psi cylinder: 1665 psi to 1485 psi.

11 Special instructions

11.1 Use of an independent air supply (supplied airline respirator (SAR) connection)

WARNING

Air quality must conform to the statutory requirements. Use of a universal emergency breathing support system (UEBSS) must comply with NIOSH and NFPA 1981 requirements. The time required for the wearer to escape to a safe area must be within the remaining breathing time of the cylinder, taking into account the remaining air content in the cylinder and the breathing rate of the wearer.

Independent air supplies must meet the following standards:

- Type-1 gaseous air as defined in: CGA Commodity Specification for Air, G-71 (grade D or higher).
- NFPA 1989 Standard on Breathing Air Quality for Fire and Emergency Services Respiratory Protection.
- Air supply pressure: 87 psi to 125 psi.
- Airline hose length: 5 feet to 300 feet (maximum working hose length must not exceed 12 individual hose lengths).
- Airline flow rate: 550 liters/minute.
- Minimum ambient temperature of operation: -25 °F (-31.7 °C).

The TX Gauge alarms and warning signals will operate as normal. The TX Gauge will show cylinder pressure when the cylinder valve is open.

- Turn on the independent air supply.
- Connect the independent air supply coupling to the secondary supply hose (see the UEBSS/SAR connection instructions for use) and breathe normally.
- Close the cylinder valve (if the whistle sounds, silence it by taking several short deep breaths or momentarily operating the lung demand valve bypass button (Fig C, Item 3)).
- If any air supply problems are encountered, proceed as follows:
 - Open the cylinder valve to return to breathing from the attached cylinder.
 - Disconnect the independent air supply coupling.
 - Leave the hazardous area by the shortest and safest escape route, if necessary.

11.2 CBRN use

The Dräger PSS 5000 Series is certified by National Institute for Occupational Safety and Health (NIOSH), for chemical, biological, radiological or nuclear (CBRN) use and by the Safety Equipment Institute (SEI) to meet the requirements of NFPA 1981. Approvals are only valid when the apparatus is used with compressed-air cylinders approved by NIOSH. Equipment configurations for CBRN use are detailed in a CBRN approval table (see CBRN approval table 3367113).

Dräger recommend that a quantitative fit test (QNFT) be performed on the face mask before use in a CBRN environment. The fit test must be conducted strictly in accordance with the requirements outlined in the OSHA Respiratory Protection Standard 29 CFR, Section 1910.134.

11.3 Cautions and limitations

CAUTIONS AND LIMITATIONS

D – Air-line respirators can be used only when the respirators are supplied with respirable air meeting the requirements of CGA G – 7.1, Grade D or higher quality.

- E – Use only the pressure ranges and hose lengths specified in the USER'S INSTRUCTIONS.
- I – Contains electrical parts that may cause an ignition in flammable or explosive atmospheres.
- J – Failure to properly use and maintain this product could result in injury or death.
- M – All approved respirators shall be selected, fitted, used, and maintained in accordance with MSHA, OSHA, and other applicable regulations.
- N – Never substitute, modify, add, or omit parts. Use only exact replacement parts in the configuration as specified by the manufacturer.
- O – Refer to User's Instructions and/or maintenance manuals for information on use and maintenance of these respirators.
- S – Special or critical user's Instructions and/or specific use limitations apply. Refer to User's Instructions before donning.

CAUTIONS AND LIMITATIONS – CBRN

- Q – Use in conjunction with personal protective ensembles that provide appropriate levels of protection against dermal hazards.
 - R – Some CBRN agents may not present immediate effects from exposure, but can result in delayed impairment, illness or death.
 - T – Direct contact with CBRN agents requires proper handling of the SCBA after each use and between multiple entries during the same use. Decontamination and disposal procedures must be followed. If contaminated with liquid chemical warfare agents, dispose of the SCBA after decontamination.
 - U – The respirator should not be used beyond 6 hours after initial exposure to chemical warfare agents to avoid possibility of agent permeation.
- EBSS – EBSS Activation or engagement of EBSS in either the donor or receiver mode changes the SCBA use to Escape-Only, approved service time for either the donor, or the receiver is no longer applicable. Additional critical cautions and limitations apply. Refer to the section EBSS in the users' instructions.

11.4 S – Special or critical users' instructions

- The EOSTI alarm set point of this SCBA is $35 \pm 2\%$ of the rated cylinder pressure. For the activation range see Section 10 (technical data).
- Minimum ambient temperature of operation: -25 °F (-31.7 °C).
- When used as a combination supplied-air respirator/self-contained breathing apparatus (SAR/SCBA), not more than 20 percent of the air supply can be used during entry.
- During supplied air use, the cylinder valve must remain closed. If the supplied air fails, open the cylinder valve and immediately proceed to fresh air.
- Supplied air source must meet the following criteria: pressure 87 psi to 125 psi, air flow rate at least 550 liters/minute.

Important Note: If it is decided to exit the working area with the airline disconnected or, in an emergency, if the air supply fails, breathe normally and immediately proceed as follows:

- Open the cylinder valve (counterclockwise) slowly, but fully, and breathe normally.
- Disconnect the hose of the independent air supply from the male coupling of the airline hose connection. Breathe normally and immediately leave the hazardous area by the shortest and safest route.

The remaining duration begins from the time of opening the cylinder valve and disconnecting the independent air supply. The time required to allow the wearer to escape to a safe area must be within the remaining air capacity (volume) of the cylinder taking into account the breathing rate of the wearer.

- Use of the RIC UAC should be by trained and competent personnel only.
- The RIC UAC must only be used to recharge a cylinder in emergency situations as defined in NFPA 1981.
- The RIC UAC filling hose is a component of the NFPA 1981 certification. Only use a filling hose which has been certified to NFPA 1981 for use in immediately dangerous to life or health (IDLH) atmospheres.
- Can not use the RIC UAC connection for second person (UEBSS).
- Can not use the RIC UAC to transfer air from one compressed-air breathing apparatus to another.
- Do not allow oil, grease or other contaminants to contact the RIC UAC connection.
- Do not attempt to disassemble or repair the RIC UAC connection.
- Caution: The secondary air supply pressure to the RIC UAC must not exceed maximum rated working pressure of the cylinder(s) being filled.
- Caution: If the pressure relief valve of the RIC UAC is activated, the SCBA must be returned to the nearest Dräger branch or agent.
- Caution: If a leak is detected while refilling in a contaminated or oxygen-deficient gaseous atmosphere, stop refilling and immediately leave the hazardous area.

11.5 UEBSS – Special or critical users' instructions

Safety Warning: Use of a Universal Emergency Breathing Support System (UEBSS) must comply with NIOSH and NFPA 1981 requirements.

Refer also to the instructions for use for the UEBSS.

- UEBSS may not be engaged or activated in donor mode after the donor End-of-Service-Time-Indicator (EOSTI) has activated.
- Users must be fully trained in the operation of UEBSS in accordance with a training program conforming to the requirements of NFPA Standards 1404, Fire Service Respiratory Protection Training and 1500, Fire Department Occupational Safety and Health Program.
- Simultaneous connection of more than two users, one donor, and one receiver, is not permitted.

The time required to allow the wearers to escape to a safe area must be within the remaining air capacity (volume) of the cylinder taking into account the breathing rate of the wearers.

12 Warranty information

Unless otherwise agreed between Dräger and the customer, the following shall apply in the event of defects of the product in material or workmanship: The customer shall contact the company where he bought the product ("Seller"). The warranty conditions agreed between the customer and the Seller shall apply. The product must be used in strict accordance with the instructions for use. Any use disregarding the instructions for use may void warranty.

13 Contact details

Any issues with the equipment, including damage, malfunction, or failure of the breathing apparatus that may present a hazard to the user should be reported to Dräger US Customer Service – Phone 1-800-437-2437.

Contact with the certification organizations may be reached at:

- NIOSH, NPPTL – Phone 1-412-386-4000
- SEI (NFPA) – 1307 Dolley Madison Blvd, Suite 3A, McLean, VA 22101, Phone 1-703-442-5732