

## 1 For your safety

### 1.1 General safety statements

- Before using this product, carefully read the instructions for use.
- Strictly follow the instructions for use. The user must fully understand and strictly observe the instructions. Use the product only for the purposes specified in the Intended Use section of this document.
- Do not dispose of the instructions for use. Ensure that they are retained and appropriately used by the product user.
- Only fully trained and competent users are permitted to use this product.
- Comply with all local and national rules and regulations associated with this product.
- Only trained and competent personnel are permitted to inspect, repair and service the product. Dräger recommends a Dräger service contract for all maintenance activities and that all repairs are carried out by Dräger.
- Properly trained service personnel must inspect and service this product as detailed in the Maintenance section of this document.
- Use only genuine Dräger spare parts and accessories, or the proper functioning of the product may be impaired.
- Do not use a faulty or incomplete product, and do not modify the product.
- Notify Dräger in the event of any component fault or failure.

### 1.2 Definitions of alert icons

Alert icons are used in this document to provide and highlight text that requires a greater awareness by the user. A definition of the meaning of each icon is as follows:

**WARNING**  
Indicates a potentially hazardous situation which, if not avoided, could result in death or serious injury.

**NOTICE**  
Indicates additional information on how to use the product.

## 2 Description

### 2.1 Product overview

The PSS® Buddy Breather is a second medium-pressure connector that integrates into the medium-pressure system of a Dräger PSS® Series breathing apparatus. It is connected into a port on the pressure reducer and provides the wearer with two connectors as follows:

- An outlet connector (female quick-connect coupling) is used for the supply of air to a second person for the purpose of rescue.
- An inlet connector (male quick-connect coupling) is used for the supply of air from an alternative medium-pressure air source for decontamination.

There is a one-way valve in the inlet connector of the PSS® Buddy Breather that normally blocks outlet air flow from the connector. A safety feature is that the outlet connector of the PSS® Buddy Breather has an actuator coupling (AC) that overrides the one-way valve if two PSS® Buddy Breathers are connected together. This ensures that if a second PSS® Buddy Breather is accidentally reverse connected during a rescue, air is still supplied to the second person.

### 2.2 Intended use

The PSS® Buddy Breather is intended for use with Dräger PSS® Series breathing apparatus, to provide the wearer with rescue and/or decontamination capabilities.

Lung demand valves, rescue hoods and other accessories used with these products must be certified Dräger components, assembled in an approved configuration. Contact Dräger for further information.

### 2.3 Approvals

The European standards, guidelines, and directives according to which this product is approved are specified in the declaration of conformity (see declaration of conformity or [www.draeger.com/product-certificates](http://www.draeger.com/product-certificates)).

### 2.4 Explanation of marking and symbols

Examples of marking on component parts of the second medium-pressure connectors are:

08/09	– Month and year of manufacture
3356812 or R21034	– Dräger part number
SF	– Standard force coupling
LF	– Low force coupling
AC	– Actuator coupling

## 3 Use

**WARNING**  
The detailed procedures described in these instructions for use shall be followed in order to avoid exposure to higher risks (e.g. air loss).

Before using the PSS® Buddy Breather it must be properly assembled and tested on a Dräger PSS® breathing apparatus. Assembly instructions (see Section 7) are included in these instructions for use for trained service personnel only.

### 3.1 Preparation for use

1. Prepare the breathing apparatus for use, including all pre-operational and functional testing, and don the breathing apparatus (see the instructions for use supplied with the breathing apparatus).
2. When required, carry out the decontamination procedure (see Section 3.2) or rescue procedure (see Section 3.3).

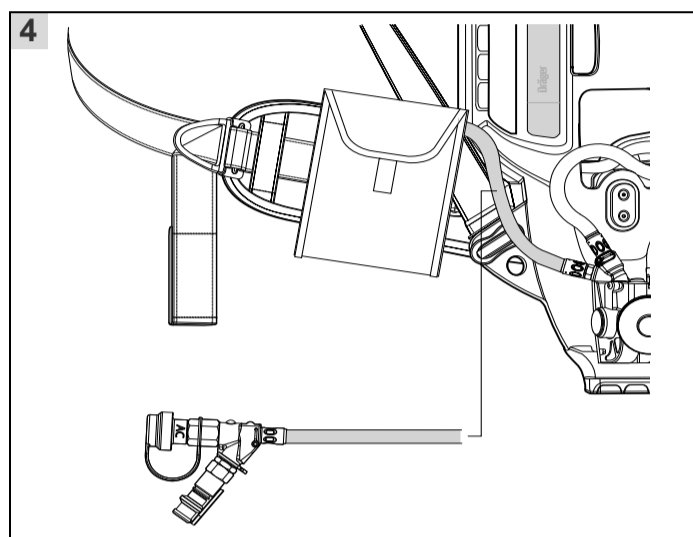
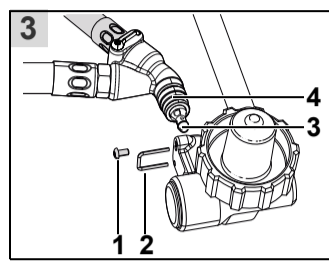
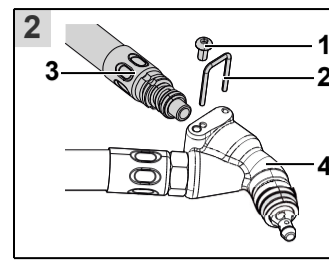
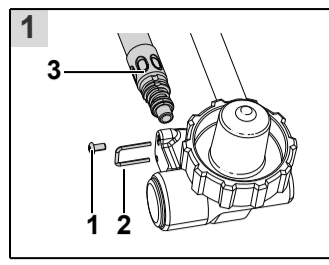

### 3.2 Decontamination procedure

**WARNING**  
Air quality for compressed air systems must conform to EN12021; do not use oxygen or oxygen enriched air.

The decontamination air supply pressure to the PSS® Buddy Breather must not exceed 10 bar. Do not attempt to connect high-pressure air.

Using an air supply that does not comply with the air quality, pressure and flow requirements could result in death or serious injury for the user.

**NOTICE**  
It is recommended that a second person monitors and maintains the decontamination air supply throughout the decontamination procedure.

**Decontamination air supply pressure and flow:**  
Operating requirement: 6 bar to 10 bar at an air flow rate of at least 550 litres/minute.

1. Ensure that the decontamination air supply complies with the air quality, pressure and flow requirements.
2. Close any relief valves fitted, and then fully open the valve of the decontamination air supply to pressurize the system.
3. Remove the PSS® Buddy Breather from the pouch.
4. Disconnect the protection cap from the inlet connector (male coupling) of the PSS® Buddy Breather and connect the hose from the decontamination air supply.

**WARNING**  
Fully close the cylinder valve of the breathing apparatus to avoid air loss from the cylinder during decontamination.

If there is any disruption to the decontamination air supply, reopen the breathing apparatus cylinder valve and immediately disconnect the decontamination air supply from the breathing apparatus.

5. Breathe normally and fully close the cylinder valve of the breathing apparatus (see the instructions for use supplied with the breathing apparatus).

**NOTICE**  
If the pressure of the decontamination air supply is higher than the medium pressure of the breathing apparatus, air may be trapped on the high-pressure side of the reducer. The gauge of the apparatus will continue to show a reading and the whistle will activate as normal as air escapes. Take several short deep breaths or briefly press the centre of rubber cover of the lung demand valve to release the trapped air.

6. When the decontamination procedure is complete, remove the breathing apparatus using one of the following methods:

**Method 1** – When the wearer is in a safe area (surrounding air is safe to breathe and all contamination sources have been removed).

1. Lift and pull forward on each of the bottom buckles of the face mask straps.
2. Positive-pressure systems only – as the seal between the face and the mask is broken, press the reset button of the lung demand valve.
3. Remove the face mask.
4. Disconnect the decontamination air supply from the PSS® Buddy Breather.
5. Refit the protection cap, coil the hose and place the PSS® Buddy Breather in the pouch.

6. Press the rubber cover at the front of the lung demand valve to vent the system fully. Press the reset button of a positive-pressure lung demand valve.
7. Remove the breathing apparatus (see the instructions for use supplied with the breathing apparatus).

**Method 2** – When the wearer is in an unsafe area (surrounding air is not safe to breathe or there are, or may be, contamination sources in the area).

**WARNING**  
The duration of the breathing apparatus air supply is dependent on the volume of air in the cylinder. The wearer commences breathing from the air cylinder when the cylinder valve is opened and the decontamination air supply is disconnected.

1. Slowly and fully open the cylinder valve of the self contained breathing apparatus.
2. Disconnect the decontamination air supply from the PSS® Buddy Breather.
3. Refit the protection cap, coil the hose and place the PSS® Buddy Breather in the pouch.
4. Breathe normally and proceed to a safe area.
5. Once in a safe area, remove the breathing apparatus (see the instructions for use supplied with the breathing apparatus).

### 3.3 Rescue procedure

**WARNING**  
Using the PSS® Buddy Breather for a rescue will reduce the duration of the air supply from the cylinder. Fully assess the risks, considering both the wearer and the person in distress, before carrying out a rescue.

**NOTICE**  
There is a one-way valve in the inlet connector (male coupling) of the PSS® Buddy Breather that normally blocks outlet air flow from the connector. Do not use the inlet connector of the PSS® Buddy Breather as an air outlet for rescue.

For a rescue operation, the PSS® Buddy Breather is connected to a lung demand valve and face mask combination, a rescue hood, or a second PSS® Buddy Breather. The recommended rescue breathing equipment is:

- PSS® Rescue Hood, or
- Dräger rescue lung demand valve (N-type with 1.75 m hose) and Dräger face mask (RA-type – normal pressure), or
- PSS® Buddy Breather.

The PSS® Buddy Breather can also be used for unplanned assistance to a second wearer of compatible breathing apparatus. Products that are compatible with the PSS® Buddy Breather are Dräger Plus and PSS® Series lung demand valves (A, AE, N and ESA), when they are connected to a face mask.

1. At the incident rescue point, remove the PSS® Buddy Breather from the pouch and disconnect the protection cap from the outlet connector (female coupling). Connect a lung demand valve and face mask combination, a rescue hood, or a second PSS® Buddy Breather to the coupling.
2. Proceed immediately to a safe area.
3. Once in a safe area, remove the breathing apparatus (see the instructions for use supplied with the breathing apparatus).
4. Disconnect the male coupling from the outlet connector of the PSS® Buddy Breather and refit the protection cap. Coil the hose and place the PSS® Buddy Breather in the pouch.

### 3.4 After use

Carry out the after use tasks detailed in the associated breathing apparatus instructions for use.

## 4 Troubleshooting

There are no user troubleshooting tasks on the PSS® Buddy Breather. Refer to the troubleshooting information in the associated breathing apparatus instructions for use, or contact Dräger or service personnel for further information.

## 5 Maintenance

Carry out routine maintenance, including cleaning and disinfecting, after each use as defined in the associated breathing apparatus instructions for use.

## 6 Storage

Store the equipment in a cool dry environment, free from dust and dirt. Do not expose to direct sunlight.

## 7 Assembly instructions

**WARNING**  
Fitting the PSS® Buddy Breather to a breathing apparatus may only be carried out by suitably trained personnel (attendance at an appropriate Dräger maintenance course is required). Fitting by untrained personnel could make the breathing apparatus unsafe for use.

**Tools Required**  
T10 driver  
Torque wrench (1.2 Nm)

1. Remove the air cylinder from the breathing apparatus (see the instructions for use supplied with the breathing apparatus).

See Figure 1.

2. Remove the screw (1) and then remove the retention staple (2) from the reducer body.
3. Remove the medium-pressure hose (3) from the port of the reducer.

**NOTICE**  
Component parts of the relief valve (spring, O-ring retainer and O-ring) remain attached to the nozzle of the medium-pressure hose. Do not remove the parts.

See Figure 2.

4. Remove the screw (1) and then the retention staple (2) from the manifold (4).
5. Insert the medium-pressure hose (3) into the manifold port, and press and hold against the spring.
6. Fully insert the retention staple (2) ensuring correct location into the groove in the hose end fitting.
7. Check that the hose is securely retained by gently pulling the hose away from the manifold.
8. Insert and tighten the screw (1) to a torque of 1.2 Nm.

See Figure 3.

9. Insert the non-return valve (3) into the bore of the manifold and ensure the O-ring (4) is properly fitted.
10. Insert the manifold connector into the port of the reducer.
11. Fully insert retention staple (2) ensuring correct location into the groove of the manifold connector.
12. Check that the manifold is securely retained by gently pulling the manifold away from the reducer body.
13. Insert and tighten the screw (1) to a torque of 1.2 Nm.

See Figure 4.

14. Fit the pouch on to the waist belt in the position shown.
15. Carry out the functional testing (Section 7.1).

### 7.1 Functional testing

Before releasing the breathing apparatus for use, perform the functional testing to ensure the integrity of the breathing apparatus and the correct function of the PSS® Buddy Breather.

#### WARNING

Failure of the breathing apparatus to meet any of the standards or parameters described in the functional tests indicates a system fault. Do not release the breathing apparatus for use until the fault condition is rectified.

#### NOTICE

Test the breathing apparatus in the normal operating position (vertical). Connecting a decontamination air supply with the apparatus in a horizontal position may activate the warning whistle of the breathing apparatus. If this occurs, disconnect the decontamination air supply, allow the system to fully vent and then reconnect with the breathing apparatus in a vertical position.

1. Prepare the breathing apparatus and lung demand valve for use, but do not connect a face mask. Carry out the leak test described in the functional testing of the breathing apparatus (see the instructions for use supplied with the breathing apparatus).
2. Slowly and fully open the cylinder valve of the breathing apparatus.
3. Disconnect the protection cap from the inlet connector of the PSS® Buddy Breather and connect the hose from the decontamination air supply.
4. Open the valve of the decontamination air supply.
5. Close the cylinder valve of the breathing apparatus.

#### WARNING

Do not direct air flow from the outlet of the lung demand valve toward the face, eyes or skin. Released air can cause serious injuries.

6. Activate an unobstructed air flow from the outlet of the lung demand valve as follows:  
Positive-pressure lung demand valve – Press the centre of rubber cover.  
Negative-pressure lung demand valve – Press and hold the centre of the rubber cover.
7. The breathing apparatus pressure gauge reading will fall to zero pressure, but decontamination air must continue to flow.
8. Switch off the air flow from the lung demand valve.

#### NOTICE

The warning whistle of the breathing apparatus must be silent.

9. Close the valve of the decontamination air supply then disconnect the decontamination hose from the connection of the PSS® Buddy Breather.
10. Following satisfactory testing, refit all protection caps, coil the hose and place the PSS® Buddy Breather in the pouch. Store the apparatus ready for use.