

Dräger NBC protection unit type SBL 100 M and Dräger NBC combination filter

The Dräger NBC protection unit type SBL 100 M is a positive-pressure ventilation system for vehicles and shelters. The unit can be placed both in the space to be protected as well as outside. The NBC combination filter has been developed to use with it, for retarding gaseous warfare agents, aerosols and dust.



ST-12B24-2004

DRÄGER NBC PROTECTION UNIT TYPE SBL 100 M

Coarse-dust (cyclone), airborne-particulate and gas filters are arranged on the pressure side of the main blower. The fresh air pumped by the Dräger NBC protection unit is cleaned of contaminants – or warfare agents in the case of the NBC. At the same time, with the hatches, doors and windows closed, a positive-pressure environment is generated in the vehicle which prevents contaminated air from penetrating into the various operating situations. The heating or air conditioning system, which is not part of the Dräger NBC protection unit, can be installed downstream of it. To reduce the sound pressure level a silencer can be connected to the clean air outlet using a pipe or hose connection. The system includes a gauge for measuring the positive pressure. The system's components and the combined gas and airborne-particulate filters deployed are manufactured in line with the technical supply conditions for the German armed forces (system components: TL 4240-0019; gas, airborne-particulate filters: TL 4240-0060).

After appropriate vehicle-side precautions have been taken, filter changing is possible from the inside to the inside, from the outside to the outside or from the inside to the outside. The protected space must be airtight enough to ensure that with a clean air volume flow of 100 m³/h a positive pressure of up to 8 mbar is reached. Air connection lines from the air inlet and dust outlet openings as well as the air connection line to the coarse-particulate filter and from the positive-pressure gauge must be provided on the vehicle.

Dräger NBC protection unit SBL 100 M is installed worldwide in, among others, the Wiesel vehicle family, the Puma armoured personnel carrier and the German army's Command and Control Information System (FülInfoSys Heer). The Dräger NBC protection unit is equipped with two Dräger NBC combination filters.



ST-21-20004

Dräger NBC protection unit SBL 100 M



ST-12407-2007

Dräger NBC combination filter



ST-16-2004

Positive pressure gauge:
printing / english E 11 486

DRÄGER NBC COMBINATION FILTER

The combination of an NBC airborne-particulate and an NBC gas filter in one housing offers the advantages that only one filter needs to be changed and only one replacement filter needs to be kept in reserve. A highly effective glass-fibre paper with water-repellent properties is used as the filter medium for the airborne-particulate filter part. Activated carbon is used for the gas filter part. The activated carbon is arranged in the filter so that it is safe from vibration and can therefore withstand mechanical impact stresses. In conformity with existing specifications such as TL 4240-0060, the Dräger ABC combination filter safely meets the retaining times against chloropicrin and chlorine cyanide. Furthermore, a long storage life is guaranteed even in extreme conditions

as the Dräger NBC combination filter is packed in water vapour-tight barrier-layer material.

Two Dräger F7 prefilters can be used to decisively prolong the life of the combination filter in dusty environments.

For exercise purposes and on peaceful deployments the Dräger NBC protection unit can be equipped with airborne-particulate filters (peace filters) instead of the combination filters. The requisite adapters for each unit are supplied with the equipment.

Dräger NBC protection unit type SBL 100 M – another quality product from Dräger Safety.



ST-3053-2004

Dräger NBC airborne-particulate filter



ST-12408-2007

Dräger F7 prefilter

TECHNICAL DATA

Dräger NBC protection unit type SBL 100 M

Weight:	51 kg with; 42 kg without filter	
Unit volume:	56 dm ³	
Coating:	TL A-0033, RAL 1013	
Air blast resistance:	1000 mbar (for a period of 500ms)	
Volume flow:	full operation: 100 m ³ /h	half operation: 50 m ³ /h
Ambient temperature:	+44 °C ; -30 °C	
Operating voltage:	24 V DC	
Power input:	full operation: 800 W	half operation: 300 W
Impact and vibration-resistant:	in accordance with TL 2350-023	

Components

Large-particulate filter (cyclone):	Dust-removal level: 98% at a volume flow of 100 m ³ /h and a raw air dust content of 1 g/m ³ with test dust "Arizona coarse"	
Main blower:	Volume flow: 120 m ³ /h Power input: 800 watt, type of protection for motor: IP 56 Degree of interference suppression: "K" or in accordance with VG 95370 Part 16 or in line with TL 2350-025 Annex 3, LA measurement method (limit curve Leopard 2)	
Filter housing:	Gas-tight aluminium construction with decontaminatable coating, RAL 6031, single-hand flap operation, quick-action closures	
Combination filter:	2 units	
Positive pressure gauge:	See data sheet for positive pressure gauge NBC protection unit	

Dräger NBC combination filter

Nominal air volume:	50 m ³ /h	
Weight (approx.):	4.7 kg	
Resistance to fluid flow:	< 40 hPa (at nominal air volume)	
Permeability:	< 0.003% (after test mist loading)	
Retaining capacity against:	C+ - value (mg x min x m ³)	[humid saturated coal] [dry coal]
	Chloropicrin	300.000 1.000.000
	Chlorzyan	140.000 280.000
	Hydr. Acid	160.000 160.000

ORDERINFORMATION

Dräger NBC protection unit SBL 100 M		on request
Dräger NBC combination filter	(2x per unit)	67 38 595
Dräger NBC airborne-particulate filter (peace filter)	(2x per unit)	67 26 312
Dräger NBC-F7 prefilter	(2x per unit)	67 38 575
Positive pressure gauge	printed in English	E 11 486

Dimensions:

Dräger NBC protection unit
SBL 100 M

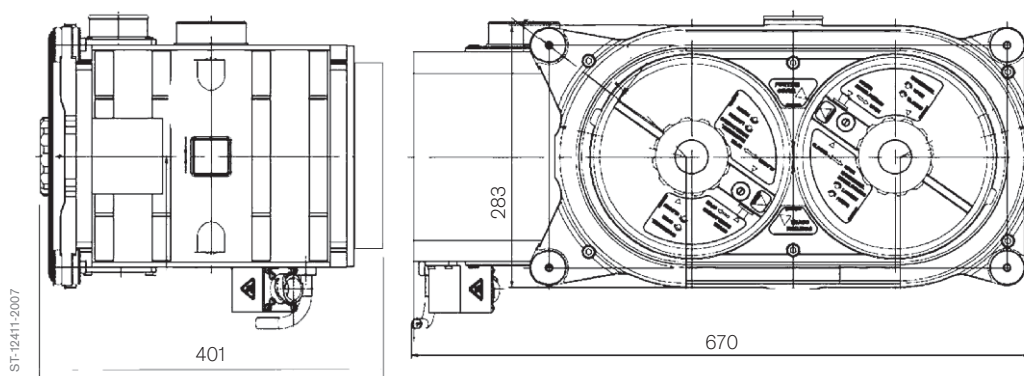

Dimensions:

Dräger NBC combination filter

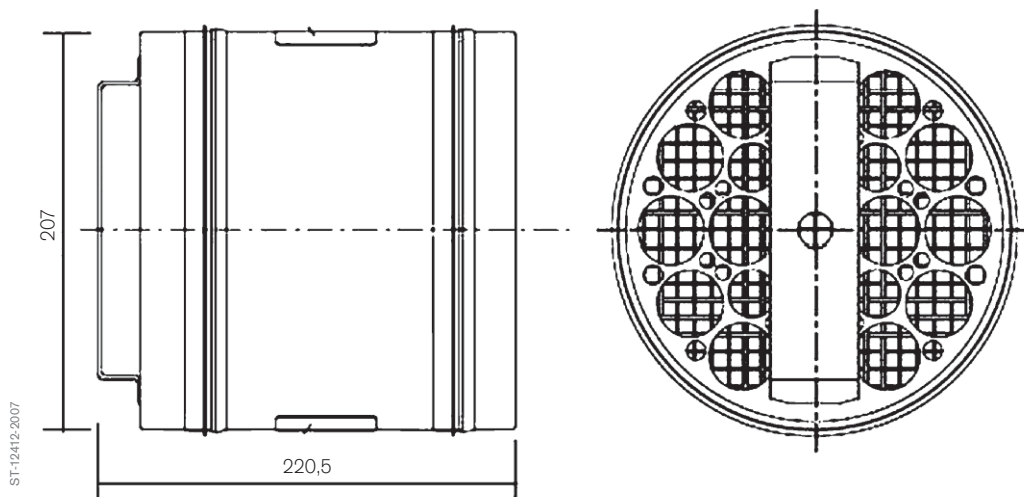

HEADQUARTERS:

Draeger Safety AG & Co. KGaA
Revalstraße 1
23560 Lübeck, Deutschland
Tel +49 451 882-0
Fax +49 451 882-2080

www.draeger.com
nbc@draeger.com

SUBSIDIARIES:**AUSTRALIA**

Draeger Safety Pacific
Pty. Ltd.
Axxess Corporate Park
Unit 99, 45 Gilby Road
Mt. Waverley, Vic 3149
Tel +61 3 92 65 50 00
Fax +61 3 92 65 50 95

CANADA

Draeger Canada Ltd.
7555 Danbro Crescent
Mississauga, Ontario
L5N 6P9
Tel +1 905 821 89 88
Fax +1 905 821 25 65

P. R. CHINA

Beijing Fortune Draeger
Safety Equipment Co., Ltd.
A22 Yu An Rd, B Area,
Tianzhu Airport Industrial Zone,
Shunyi District, Beijing 101300
Tel +86 10 80 49 80 00
Fax +86 10 80 49 80 05

FRANCE

Draeger Safety France SAS
3c route de la Fédération,
BP 80141
67025 Strasbourg Cedex 1
Tel +33 3 88 40 59 29
Fax +33 3 88 40 76 67

MEXICO

Draeger Safety S.A. de C.V.
Av. Peñuelas No. 5,
Bodega No. 37
Fraccionamiento Industrial
San Pedrito
Querétaro, Qro México
Tel +52 442 246-1113
Fax +52 442 246-1114

NETHERLANDS

Draeger Safety Nederland B.V.
Edisonstraat 53
2700 AH Zoetermeer
Tel +31 79 344 46 66
Fax +31 79 344 47 90

SINGAPORE

Draeger Safety Asia Pte Ltd
67 Ayer Rajah
Crescent #06-03
Singapore 139950
Tel +65 68 72 92 88
Fax +65 65 12 19 08

REP. OF SOUTH AFRICA

Draeger South Africa
(Pty) Ltd.
P.O.Box 68601
Bryanston 2021
Tel +27 11 465 99 59
Fax +27 11 465 69 53

SPAIN

Draeger Safety
Hispania S.A.
Calle Xaudaró 5
28034 Madrid
Tel +34 91 728 34 00
Fax +34 91 729 48 99

UNITED KINGDOM

Draeger Safety UK Ltd.
Blyth Riverside
Business Park
Blyth, Northumberland
NE24 4RG
Tel +44 1670 352 891
Fax +44 1670 356 266

USA

Draeger Safety, Inc.
101 Technology Drive
Pittsburgh, PA 15275
Tel +1 412 787 83 83
Fax +1 412 787 22 07